

OPERATION MANUAL

UFM-145DFS Time Base Corrector

2nd Edition - Rev. 2



Precautions

Important Safety Warnings

[Power]

 Stop	<p>Do not place or drop heavy or sharp-edged objects on power cord. A damaged cord can cause fire or electrical shock hazards. Regularly check power cord for excessive wear or damage to avoid possible fire / electrical hazards.</p>
---	--

[Circuitry Access]

 Stop	<p>Do not touch any parts / circuitry with a high heat factor. Capacitors can retain enough electric charge to cause mild to serious shock, even after power is disconnected. Capacitors associated with the power supply are especially hazardous. Avoid contact with any capacitors.</p>
 Hazard	<p>Unit should not be operated or stored with cover, panels, and / or casing removed. Operating unit with circuitry exposed could result in electric shock / fire hazards or unit malfunction.</p>

[Potential Hazards]

 Caution	<p>If abnormal smells or noises are noticed coming from the unit, turn power off immediately and disconnect power cord to avoid potentially hazardous conditions. If problems similar to above occur, contact authorized service representative before attempting to again operate unit.</p>
---	---

[Consumables]

 Caution	<p>The consumables used in unit must be replaced periodically. For further details on which parts are consumables and when they should be replaced, refer to the specifications at the end of the Operation Manual. Since the service life of the consumables varies greatly depending on the environment in which they are used, they should be replaced at an early date. For details on replacing the consumables, contact your dealer.</p>
--	--

Upon Receipt

Unpacking

UFM-145DFS units and their accessories are fully inspected and adjusted prior to shipment. Operation can be performed immediately upon completing all required connections and operational settings.

Check your received items against the packing lists below.

ITEM	QTY	REMARKS
UFM-145DFS	1	
Operation Manual	1	

Check

Check to ensure no damage has occurred during shipment. If damage has occurred, or items are missing, inform your supplier immediately.

Option

ITEM	QTY	REMARKS
UFM-100AED	1	Audio embedder / de-embedder module
UFM-100AIO	1	Input / Output module for UFM-100AED

Table of Contents

1. Prior to Starting	1
1-1. Welcome	1
1-2. About the UFM-145DFS	1
1-3. About This Manual	1
2. Panel Descriptions	2
2-1. Front Panel	2
2-2. Rear Panel	4
3. Connection	5
3-1. Basic Connection	5
3-2. GENLOCK Connection	6
4. Operation	7
4-1. Front Panel Controls	7
4-2. Front Panel Operations	8
4-2-1. UNITY/OPERATE	8
4-2-2. VIDEO LEVEL	8
4-2-3. CHROMA LEVEL	9
4-2-4. SETUP/BLACK	9
4-2-5. CHROMA PHASE	9
4-2-6. H PHASE	10
4-2-7. INPUT SELECT	10
4-2-8. FREEZE	11
5. Internal Setting	12
5-1. Dipswitch Settings	12
5-2. Jumper Settings	16
5-2-1. GENLOCK Setting	16
5-2-2. Sync Adjust Setting	17
5-2-3. Factory Default Settings	17
6. If Problems Occur	18
7. Specifications & Dimensions	19
7-1. Unit Specifications	19
7-2. External Dimensions	20

1. Prior to Starting

1-1. Welcome

Congratulations! By purchasing UFM-145DFS you have entered the world of FOR-A and its many innovative products. Thank you for your patronage and we hope you will turn to FOR-A products again and again to satisfy your video and audio needs.

1-2. About the UFM-145DFS

The UFM-145DFS is a plug-in type unit that is used by mounting to the Universal Frame Series (UFM frames). Designed by using the latest technology, the UFM-145DFS provides high quality time base correction / frame synchronization performance at a reasonably low cost.

Besides providing the excellent support our customers have come to expect from FOR-A signal processors, that correct by up to one full frame the time base error / phase shift problems that can occur during record / playback of analog composite signals when using heterodyne process VCRs and provides analog component processing support.

Features

- SD-SDI video input / output standard.
- Analog composite video input / output standard.
- 4:2:2 digital component signal processing.
- 10-bit digital Y/C separation/decoding/encoding.
- Full frame memory to prevent picture field inversion during processing.
- 10-bit quantization each for Y and C.
- Hot swap module.
- SDI formats. 625/50, 525/60, auto detection.

1-3. About This Manual

This manual is intended to help the user easily operate the UFM-145DFS and make full use of its functions during operations. Before connecting or operating your unit, read this operation manual thoroughly to ensure you understand the UFM-145DFS. After reading, it is important to keep this manual in a safe place and available for reference.

2. Panel Descriptions

2-1. Front Panel

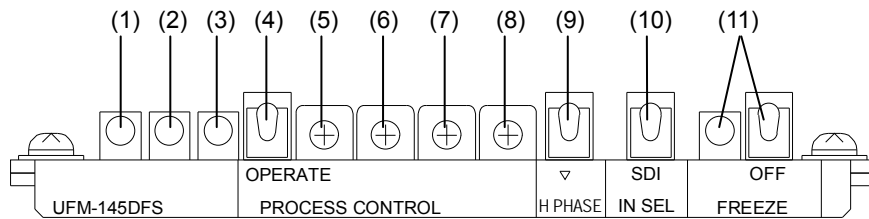

(1) Power indicator

Indicator status	Indication
Lit	Lit green when power switch is set to ON and power applied to the unit.
Unlit	Unlit when power is not applied to the unit.

(2) INPUT indicator

Indicator lights green whenever video signal (s) is inputted to the unit.

Indicator status	Indication
Lit	Receiving video signal input and the unit is working properly.
Unlit	No input video signals. Input level too low Off video random noise.
Flashing	Sync signal is considerably unstable. Sync signal has dropout.

(3) GENLOCK indicator

Indicator lights green whenever UFM-145DFS signal is synced (LOCK) with the external black burst (B.B.) which is input to the universal frame REF connector or rear panel GENLOCK connector of the module.

Indicator status	Indication
Lit	UFM-145DFS signal synced to external reference signal input.
Unlit	No external reference signal input. Input level too low Internal timing signal used for reference.
Flashing	External reference signal not stable. Check external signal input.

(4) UNITY / OPERATE switch

UNITY	Sets all processes settings for (5) , (6) , (7) and (8) to UNITY at the same time. (UNITY default setting)
OPERATE	Process controls (5) , (6) , (7) and (8) at front panel can be used to adjust signal processing parameters.

(5) VIDEO LEVEL

Used to adjust video level.
See sec. "4-2-2. VIDEO LEVEL."

(6) CHROMA LEVEL

Used to adjust chroma level.
See sec. "4-2-3. CHROMA LEVEL."

(7) SETUP / BLACK

Used to adjust setup level.
See sec. "4-2-4. SETUP / BLACK."

(8) CHROMA PHASE

Used to adjust chroma phase.
See sec. "4-2-5. CHROMA PHASE."

(9) H PHASE SWITCH

See sec. "4-2-6. H PHASE"

(10) INPUT SELECT SWITCH

See sec. "4-2-7. INPUT SELECT"

(11) FREEZE and indicator

Used to set freeze operation ON / OFF. Indicator lights green whenever freeze is set to ON. The freeze operation is set to ON when the switch is in the upper position. The operation is set to OFF when set to the lower position.
See sec. "4-2-8. FREEZE."

2-2. Rear Panel

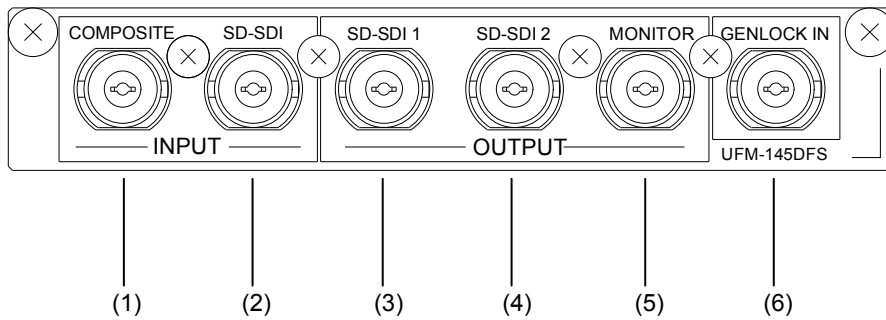

(1) COMPOSITE IN

Used for COMPOSITE video input connection.

(2) SD-SDI IN

Used for SD-SDI video input connection.

(3) SD-SDI OUT 1

Used to output the SD-SDI signal, corrected video input from (1) COMPOSITE IN or (2) SD-SDI IN, and bypass signal from input connector (2) whenever the unit power is off.

(4) SD-SDI OUT 2

Used to output SD-SDI signal.

Used to output corrected video input from (1) COMPOSITE IN or (2) SD-SDI IN.

(5) MONITOR OUT / GENLOCK THRU

Used to output MONITOR OUT or GENLOCK THRU signal based on the internal jumper settings.

Factory setting is MONITOR OUT. Refer to sec. "5-2. Jumper Settings" for more details.

NOTE

Since this is an HLOCK system, the external burst signal and subcarrier phase cannot be aligned.

(6) GENLOCK

Used to input an external reference signal whenever the internal sync generator needs to be genlocked with it. The available input signal is 0.429 Vp-p composite black burst (for NTSC) or 0.450 Vp-p composite black burst (for PAL).

Connector (5) can also be used for GENLOCK THRU (genlock loopthrough) using an internal setting. If connector (5) is set to GENLOCK THRU and is not connected to another system, the connector must be 75 Ω terminated using a terminator supplied by the user or an internal jumper setting. (See sec. "5-2. Jumper Setting".)

Front panel GENLOCK indicator lights green whenever UFM-145DFS signal is synced with external black burst reference signal input here.

3. Connection

 <p>CAUTION</p>	<p>Turn all the power OFF before making connection.</p>
--	---

3-1. Basic Connection

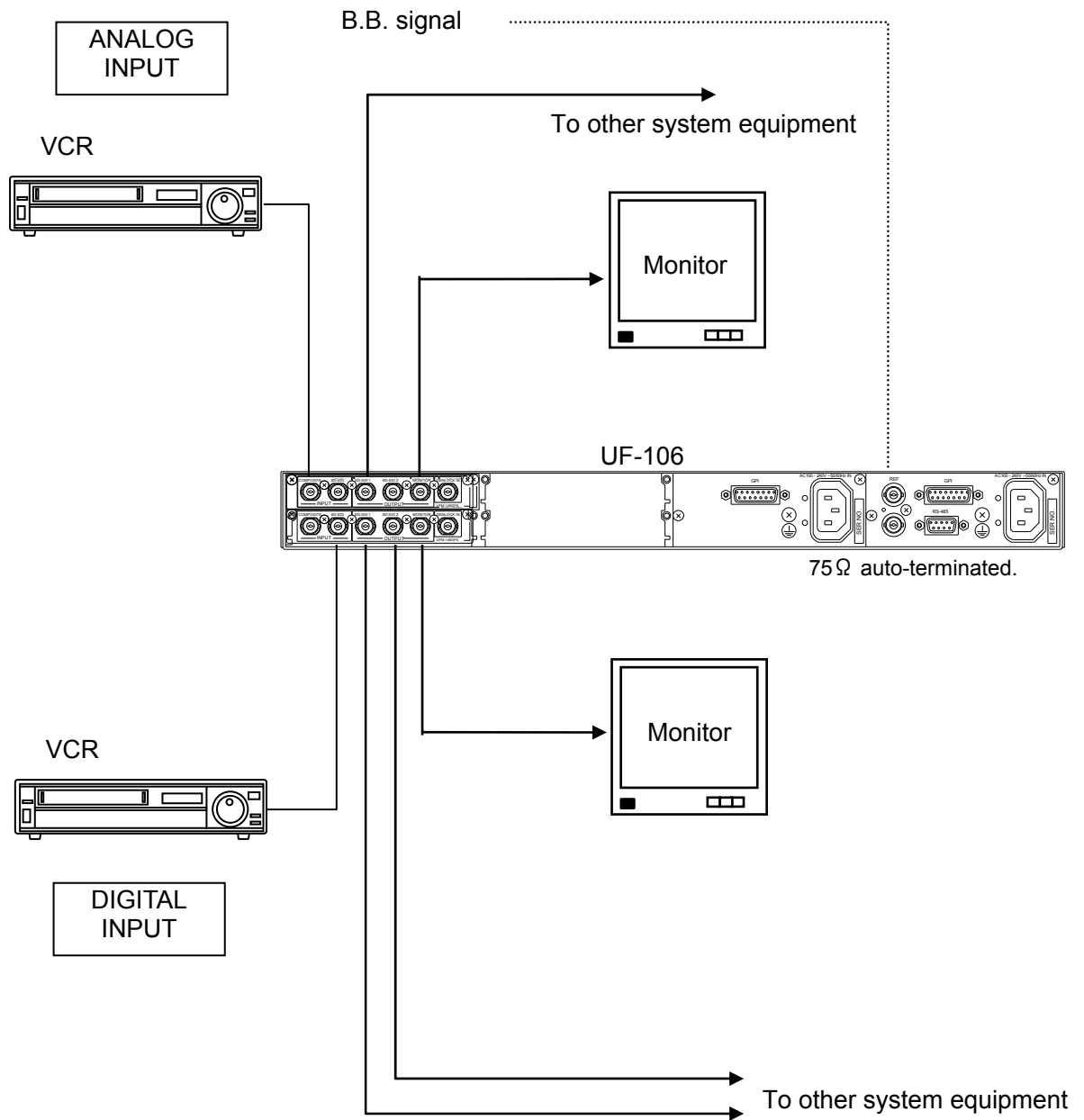

3-2. GENLOCK Connection

If output connector (5) is switched from MONITOR OUT to GENLOCK THRU, multiple units can be configured as shown in the figure below. (See sec."5-2. Jumper Setting.") The factory default setting is MONITOR OUT.

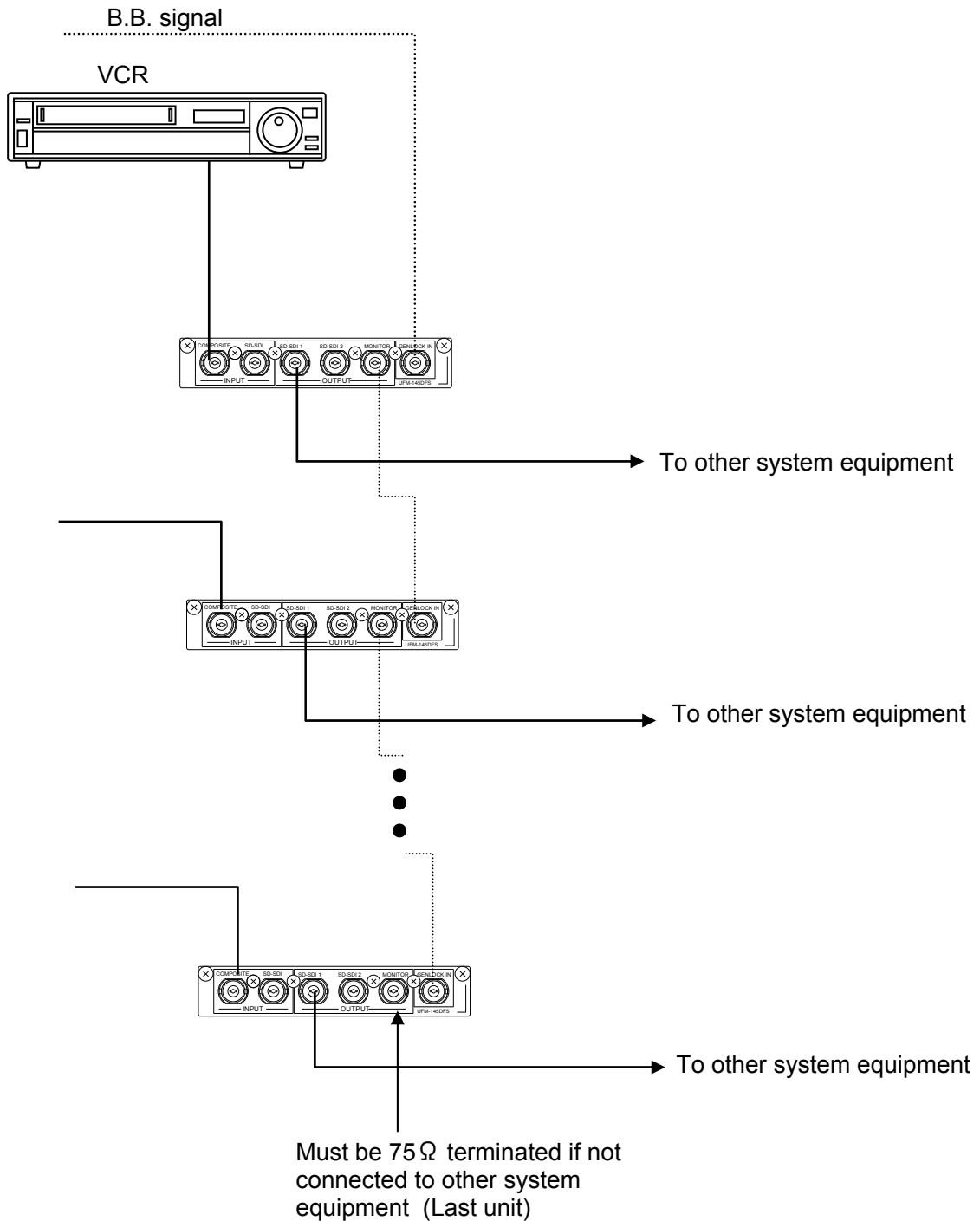

4. Operation

4-1. Front Panel Controls

The UFM-145DFS front panel controls can be used to select and change operational settings and levels and to make settings in the operational menus.

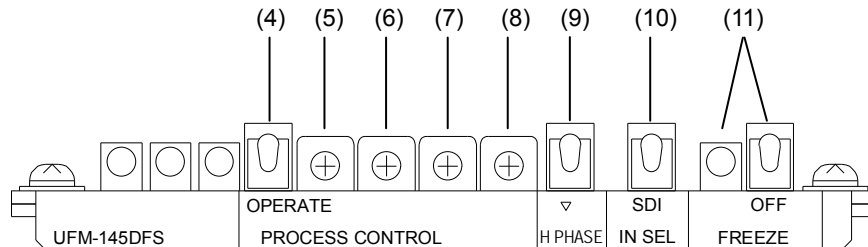

Switch and Controls	Factory Set Default	Reference
(4) UNITY/OPERATE	UNITY	4-2-1
(5) VIDEO LEVEL	CENTER	4-2-2
(6) CHROMA LEVEL	CENTER	4-2-3
(7) SETUP/BLACK	CENTER	4-2-4
(8) CHROMA PHASE	CENTER	4-2-5
(9) H PHASE CONTROL	0	4-2-6
(10) INPUT SELECT	COMPOSITE	4-2-7
(11) FREEZE	OFF	4-2-8

4-2. Front Panel Operations

4-2-1. UNITY/OPERATE

Set the switch to the upper or lower positions to switch between UNITY and OPERATE.

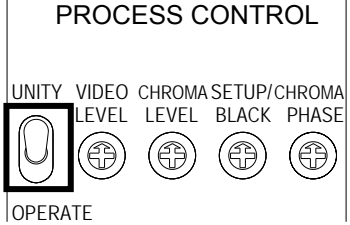
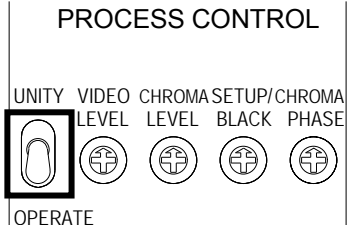
Switch and Controls	Description
<p>Upper position (UNITY)</p>	
<p>Lower position (OPERATE)</p>	

All process control settings are disabled and return to the default settings.

Following process controls will be enabled:
 VIDEO LEVEL
 CHROMA LEVEL
 SETUP/BLACK
 CHROMA PHASE

4-2-2. VIDEO LEVEL

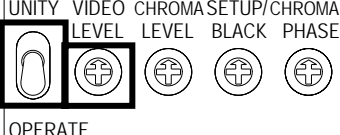
Switch and Control	Description
<p>UNITY/OPERATE: Lower position (OPERATE)</p>	<p>Adjusts luminance level</p> <p>Setting range: -3dB to +3dB</p>
<p>Turn the VIDEO LEVEL control to adjust</p>	

4-2-3. CHROMA LEVEL

Switch and Control		Description
UNITY/OPERATE: Lower position (OPERATE)	<p style="text-align: center;">PROCESS CONTROL</p> <p style="text-align: center;">UNITY VIDEO CHROMA SETUP/CHROMA LEVEL LEVEL BLACK PHASE</p> <p style="text-align: center;">OPERATE</p>	Adjusts chroma level.
Turn the CHROMA LEVEL control to adjust		Setting range: -3dB to +3dB

4-2-4. SETUP/BLACK

Switch and Control		Description
UNITY/OPERATE: Lower position (OPERATE)	<p style="text-align: center;">PROCESS CONTROL</p> <p style="text-align: center;">UNITY VIDEO CHROMA SETUP/CHROMA LEVEL LEVEL BLACK PHASE</p> <p style="text-align: center;">OPERATE</p>	Adjusts setup black level. Turning the control clockwise brightens the setup black.
Turn the SETUP/BLACK control to adjust.		Setting range: -15 to +15IRE

4-2-5. CHROMA PHASE

Switch and Control		Description
UNITY/OPERATE: Lower position (OPERATE)	<p style="text-align: center;">PROCESS CONTROL</p> <p style="text-align: center;">UNITY VIDEO CHROMA SETUP/CHROMA LEVEL LEVEL BLACK PHASE</p> <p style="text-align: center;">OPERATE</p>	Adjusts chroma phase.
Turn the CHROMA PHASE control to adjust.		Setting range: -30° to +30°

4-2-6. H PHASE

Switches		Description
H PHASE:		Used to adjust the H phase difference between the genlock input and video output signals.
Move the switch upward or downward position.		Upward: Moves H phase forward. Downward: Moves H phase backward. Setting range: $-2\mu\text{s}$ to $+2\mu\text{s}$ (Factory default: $0\mu\text{s}$)

IMPORTANT

H PHASE is set to 0 at factory shipment. You should reset this parameter to match the reference signal of your system.
 Note that it takes approximately 1 second until the new setting takes effect. When turning the unit OFF, wait at least 1 second after the setting.

4-2-7. INPUT SELECT

Switches		Description
INPUT SELECT:		Used to input video signals selection.
		Upward: COMPOSITE IN. Downward: SD-SDI IN.

4-2-8. FREEZE

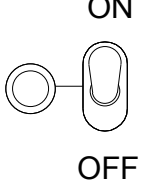
Switch	Description	
<p style="text-align: center;">FREEZE</p> <div style="text-align: center;">  </div> <p style="text-align: center;">OFF</p>	<p>Sets FREEZE mode ON/OFF. Left indicator lit green when FREEZE ON.</p> <p>FRAME or FIELD freeze can be set.</p>	
	<p>FRAME FREEZE</p> <p>FRAME freeze gives a clearer picture if the video contains few moving elements.</p>	<p>FIELD FREEZE</p> <p>FIELD freeze gives a picture with fewer jitters if the video contains rapid moving elements.</p>
	<p>FRAME/FIELD is selected by using the internal dipswitch settings. Factory default is FRAME. See sec. "5-1. Dipswitch Settings."</p> <p>ODD or EVEN field can be selected when using the FIELD setting. This is done using the internal dipswitch settings. See sec. "5-1. Dipswitch Settings."</p>	

5. Internal Setting

5-1. Dipswitch Settings

Following settings can be made at dipswitch SW1 and SW2 on the MAIN CARD.

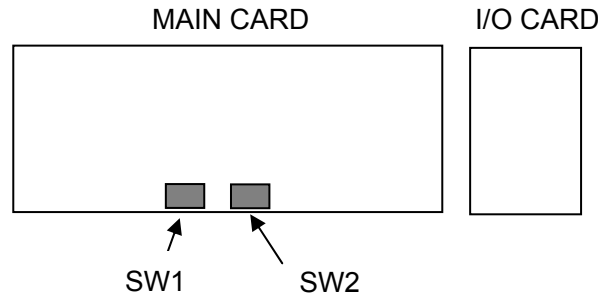

Dipswitch SW1

Pin No.	Item	Setting		Factory Set
		OFF	ON	
1	FACTORY SETTING	—	—	OFF
2	TEST SIGNAL	—	COLOR BAR	OFF
3	FREEZE MODE SELECT	FRAME	FIELD	OFF
4	FIELD SELECT	ODD	EVEN	OFF
5	AUTO FREEZE	OFF	ON	OFF
6	FORCED FIELD	OFF	ON	OFF
7	B/W	OFF	ON	OFF
8	VITS	OFF	ON	OFF

- ◆ **FACTORY SETTING (SW1-1)**
Do not change this setting.
- ◆ **TEST SIGNAL (SW1-2)**
Sets internal color bar ON/OFF.
- ◆ **FREEZE MODE SELECT (SW1-3)**
Used to select FRAME or FIELD freeze.
- ◆ **FIELD SELECT (SW1-4)**
Used to select ODD or EVEN field when FIELD freeze is set to SW1-3 or a half frame output is set to SW1-6.
- ◆ **AUTO FREEZE (SW1-5)**
Sets AUTO FREEZE ON/OFF.
Used to freeze last received normal field of video input signal to compensate for input dropout due to signal loss.

NOTE

Off video random noise is considered to be signal loss.
Once the video is frozen, freeze mode is not released until a normal video input is received or AUTO FREEZE is set to OFF.

◆ **FORCED FIELD (SW1-6)**

Used to select half frame output ON/OFF.

When set to ON, either the ODD or EVEN field will be output from the VIDEO OUT connector on the rear panel. ODD/EVEN is selected at SW1-3.

◆ **B/W (SW1-7)**

Used to select B/W or color video output from rear panel VIDEO OUT connectors.

ON = Black and white video output.

OFF = Color video output.

NOTE
B/W video is output when set to ON even if color video signals are input. In this case, the B/W video output still contains the color burst signal.

◆ **VITS (SW1-8)**

COMPOSITE IN

ON = If VITS signal is included in the input video, it is also included in the output signals.
(Inserted to 10-21H vertical blanking interval)

OFF = No VITS signal is included in output signals. Vertical blanking interval is 0H-20H.

SD-SDI IN

No VITS signal is included in output signals.

Dipswitch SW2

Pin No.	Item	Setting		Factory Set
		OFF	ON	
1	REMOTE	LOCAL	REMOTE	OFF
2	SET UP	OFF	ON	OFF
3	SYNCHRO MODE	FRAME	LINE	OFF
4	EDH	EDH ON	EDH OFF	OFF
5	REF SEL MODE	AUTO	MANUAL	OFF
6	REF SEL	REAR BNC	SYSTEM	OFF
7	NTSC/PAL	INPUT	GENLOCK	OFF
8	FACTORY SETTING	—	—	OFF

◆ **REMOTE (SW2-1)**

Used to select remote control. If set to ON(REMOTE), front panel control cannot be used.

◆ **SET UP (SW2-2)**

Set to ON when processing the input video signal with setup. (US mode)

◆ **SYNCHRO MODE (SW2-3)**

Set SYNCHRO MODE = LINE (SW2-3 = ON), if you want to lock input signal to the H sync of the input reference genlock and to minimize input/output delay. In this case, the delay will vary depending on the reference signal delay and video signal format. (See the table below.)

Input video signal	Reference signal delay	Input/Output delay of the video signal
SD SDI	1 μ s or more	Reference signal delay
	Less than 1 μ s	Reference signal delay plus 1H
Composite (NTSC)	4 μ s or more	Reference signal delay plus 1H
	Less than 4 μ s	Reference signal delay plus 2H
Composite (PAL)	5 μ s or more	Reference signal delay plus 2H
	Less than 5 μ s	Reference signal delay plus 3H

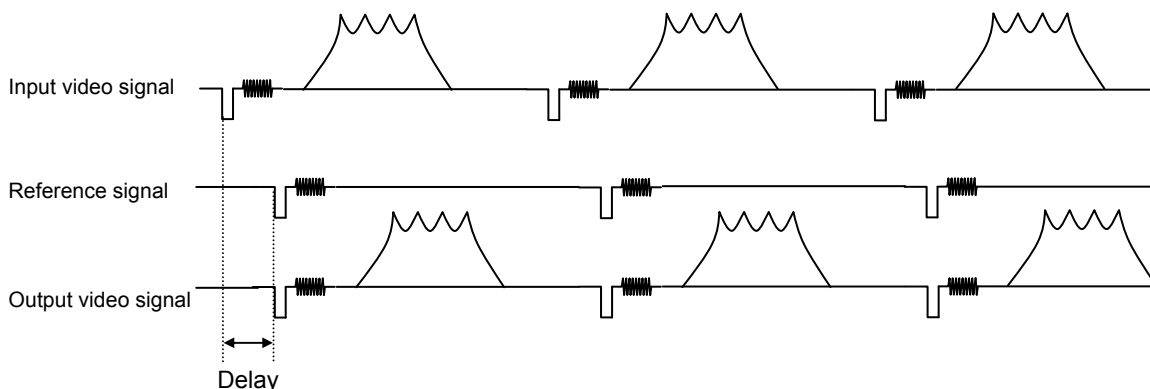

IMPORTANT

To use SYNCHRO MODE = LINE in your system, the reference signal must be synchronized with the input video signal. Otherwise, this mode doesn't work properly. (The GENLOCK indicator flashes when the synchronization fails.)

◆ **EDH (SW2-4)**

Set to OFF (EDH ON) when embedding an EDH (Error Detection and Handling) data to a signal output from SD_SDI OUT1 and 2.

◆ **REF SEL MODE (SW2-5)**

Used to set the external reference signal selection mode.

AUTO: Auto selection (The reference signal set at REF SEL (SW2-6) is used if both signals are available.)

MANUAL: External reference signal set at REF SEL (SW2-6) is used.

◆ **REF SEL (SW2-6)**

Used to select which reference signal to be used; the reference signal from the GENLOCK IN connector on the module or reference signal from GENLOCK connector on the universal frame unit.

SYSTEM: Reference signal from GENLOCK connector on the universal frame is used.

REAR BNC: Reference signal from GENLOCK IN connector on the module is used.

◆ **NTSC/PAL (SW2-7)**

Used to select which signal to be used for NTSC/PAL signal auto detection.

OFF (INPUT): Input video signal (Composite or SD SDI) is used

ON (GENLOCK): External reference signal (Genlock signal) is used.

◆ **FACTORY SETTING (SW2-8)**

Do not change this setting.

5-2. Jumper Settings

The following settings can be made at the jumpers on MAIN CARD inside the UFM-145DFS.

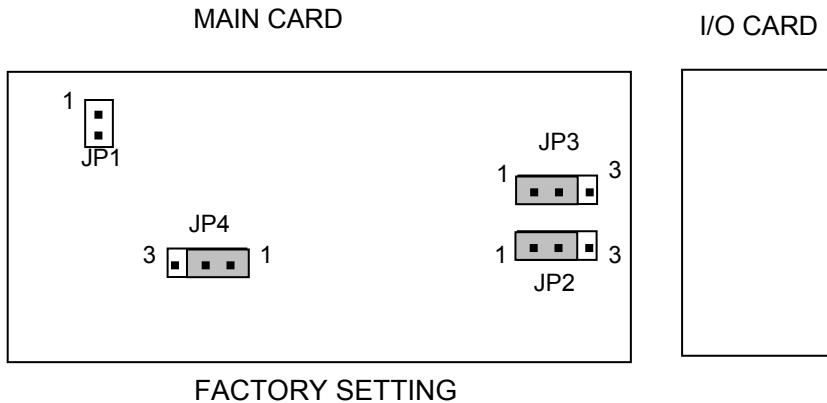

5-2-1. GENLOCK Setting

Jumper JP2 is used to select MONITOR OUT /GENLOCK THRU . Jumper JP3 is used to select GENLOCK termination ON/OFF. The related circuitry for user-fabricated control devices as shown below.

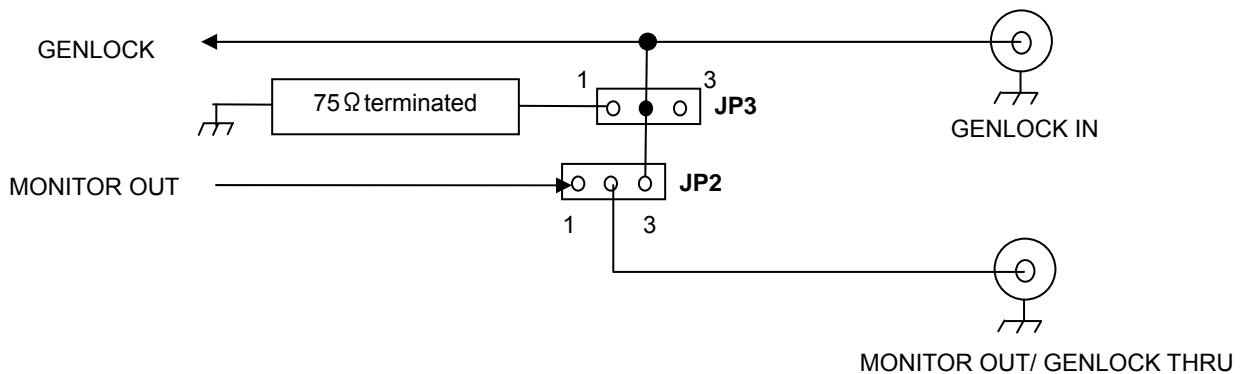

◆ **MONITOR OUT, GENLOCK terminated set**



◆ **GENLOCK THRU, GENLOCK not terminated set**



NOTE

If set to GENLOCK THRU, termination cannot be set.

5-2-2. Sync Adjust Setting

The output signal can be degraded, if the composite signal input to the unit has been deteriorated. In this case, set the jumper (JP4) to pins 2-3 shorted to make the VR22 enabled and adjust VR22 to reduce the signal degradation.

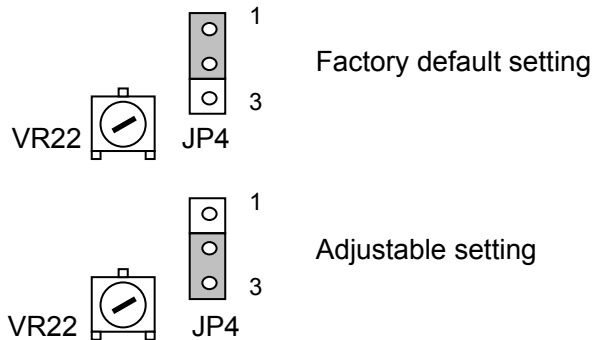

5-2-3. Factory Default Settings

If the jumper settings are changed by mistake, refer to the table below to return them to the default settings.

JP NO.	Setting
JP1	Open
JP2	1-2 short
JP3	1-2 short
JP4	1-2 short

Do not change the settings in the shaded sections of the table above from their default settings.

6. If Problems Occur

If any of the following problems occur during operation of your unit, proceed as indicated below to see if problem can be corrected before assuming a unit malfunction has occurred.

Problem	Check	Action
Cannot use process controls	UNITY / OPERATE switch	If UNITY (upper) , move the switch to OPERATE (lower) position. See sec. "2-1. Front Panel."
Input video signal not bypassed when power OFF.	SD-SDI OUT1 connection (rear panel)	Only SD-SDI OUT1 has bypass output. See sec. "2-2. Rear Panel."
Output video B/W (color signal input)	B/W setting (dipswitch)	If ON, change to OFF. See sec. "5-1. Dipswitch Settings."
Output video frozen, FREEZE not set to ON	Verify video signal is input to VIDEO IN connector.	Verify video signal is input properly. See sec. "2-2. Rear Panel."
	AUTO FREEZE setting (dipswitch)	If ON, and signal has dropout or has been lost, freeze frame will be output. See sec. "5-1. Dipswitch Settings."
No output signal from MONITOR OUT connector.	MONITOR OUT / GENLOCK THRU setting (jumper setting)	If GENLOCK THRU, change to MONITOR OUT See sec."5-2. Jumper Setting."
No output signal from all video outputs (Black screen).	FREEZE SWITCH	Verify that the FREEZE is set to OFF (bottom side) when the unit is powered on. If set to ON (top side), change to OFF. See sec. "2-1. Front Panel."
GENLOCK indicator is flashing.	SYNCHRO MODE setting (dipswitch)	Verify that the reference signal and the input video signal are properly synchronized. If not, set SYNCHRO MODE to FRAME.

7. Specifications & Dimensions

7-1. Unit Specifications

Video Format	525/60 (NTSC) or 625/50 (PAL) (Auto detect)
Video Input	Selectable as below Analog composite: 1.0 Vp-p 75Ω BNC x 1 Digital component: 270 Mbps 75Ω BNC x 1
Genlock Input	BB: 0.429 Vp-p (NTSC)/0.45 Vp-p (PAL) 75Ω, BNC x 1
Video Output	Analog composite: 1.0 Vp-p 75Ω BNC x 1 (for monitoring)* Digital component: 270 Mbps 75Ω BNC x 2
Signal Processing	4:2:2 component
Correction Range	2 fields (field inversion prevented)
Sampling Frequency	Y: 13.5 MHz, C: 6.75 MHz
Quantization	10-bit
Frequency Response	100 kHz - 4.2 MHz: -0.5 dB - +0.5 dB, 4.2 MHz - 5.0 MHz: -1.0 dB - +1.0 dB, roll off above 5.0 MHz (NTSC) 100 kHz - 5.0 MHz: -0.5 dB - +0.5 dB, 5.0 MHz - 5.5 MHz: -1.0 dB - +1.0 dB, roll off above 5.5 MHz (PAL)
S/N Ratio	56 dB
DG/DP	1.5% / 1.5° (APL: 50%)
K-Factor (2T Pulse)	Less than 1%
H/V Tilt	Less than 1%
Proc Amp	Video Level: -3 dB to +3 dB Chroma Level: -3 dB to +3 dB Setup Level: -15 IRE to +15 IRE Chroma Phase: -30° to +30°
Genlock Phase Control	H phase: -2 μs to +2 μs
Temperature	10°C to 40°C
Humidity	30% to 90% (no condensation)
Power	Supplied from UFM frame, +12 VDC to +24 VDC, 12 VA (12W)
Dimensions	106 (W) x 303 (D) mm (Front board) 108.5 (W) x 66.1 (D) mm (Rear board)
Weight	0.5 kg
Slot Requirement	1 slot
Accessories	Operation manual
Option	UFM-100AED: Audio multiplexer/demultiplexer

* SC phase of Analog Composite output does not sync with system phase.

Warning

This equipment has been tested and found to comply with the limits for a Class A digital device, pursuant to Part 15 of FCC Rules. These limits are designed to provide reasonable protection against harmful interference when the equipment is operated in a commercial environment. This equipment generates, uses, and can radiate radio frequency energy and, if not installed and used in accordance with the instruction manual, may cause harmful interference to radio communications. Operation of this equipment in a residential area is likely to cause harmful interference, in which case the user will be required to correct the interference at his own expense.



FOR-A COMPANY LIMITED

Head Office 3-8-1 Ebisu, Shibuya-ku, Tokyo 150-0013, Japan
Overseas Division Phone: +81(0)3-3446-3936, Fax: +81(0)3-3446-1470
Japan Branch Offices Osaka/Okinawa/Fukuoka/Hiroshima/Nagoya/Sendai/Sapporo
R&D/Production Sakura Center/Sapporo Center

FOR-A America Corporate Office

11155 Knott Ave., Suite G&H, Cypress, CA 90630, USA
Phone: +1-714-894-3311 Fax: +1-714-894-5399

FOR-A America East Coast Office

2 Executive Drive, Suite 670, Fort Lee Executive Park, Fort Lee, NJ 07024, USA
Phone: +1-201-944-1120 Fax : +1-201-944-1132

FOR-A America Distribution & Service Center

2400 N.E. Waldo Road, Gainesville, FL 32609, USA
Phone: +1-352-371-1505 Fax: +1-352-378-5320

FOR-A Corporation of Canada

346A Queen Street West, Toronto, Ontario M5V 2A2, Canada
Phone: +1-416-977-0343 Fax: +1-416-977-0657

FOR-A Latin America & the Caribbean

5200 Blue Lagoon Drive, Suite 760, Miami, FL 33126, USA
Phone: +1-305-931-1700 Fax: +1-305-264-7890

FOR-A UK Limited

UNIT C71, Barwell Business Park, Leatherhead Road, Chessington Surrey, KT9 2NY, UK
Phone: +44(0)20-8391-7979 Fax: +44(0)20-8391-7978

FOR-A Italia S.r.l.

Via Volturmo 37, 20047 Brugherio MB, Italy
Phone: +39-039-881-086/103 Fax: +39-039-878-140

FOR-A Corporation of Korea

1007, 57-5, Yangsan-ro, Yeongdeungpo-gu, Seoul 150-103, Korea
Phone: +82(0)2-2637-0761 Fax: +82(0)2-2637-0760

FOR-A China Limited

708B Huateng Bldg., No. 302, 3 District, Jinsong, Chaoyang, Beijing 100021, China
Phone: +86(0)10-8721-6023 Fax: +86(0)10-8721-6033

FOR-A Middle East-Africa Office

Jebel Ali Free Zone, LOB-16, Office 619, P. O. Box: 261914 Dubai, UAE
Phone: +971 4 887 6712 Fax: +971 4 887 6713

*The contents of this manual are subject to change without notice.